



Features

Ease of installation. Simply remove plastic protection strip from adhesive and place.

Blocks unwanted airflow blowing to the side of rack.

Non-Intrusive Design allows installation in conjunction with existing cabling.

Manage Cables And Unwanted Airflow

EziBlank Brush 1000 panels are designed to block airflow on the side of the racks. The non-intrusive design allows the brush panel to be installed in conjunction with existing cabling.

It comes in 1000mm long strip with 100mm long bristle and a high quality self adhesive strip for EZI installation.

Specifications:

Physical

Dimensions: 105 x 1000 x 20 (mm)

Shipping Dimensions: 101 x 12 x 3 (cm)

Weight: 0.7 kg

Material: Aluminium

Conformance

Standards:

Dimensions

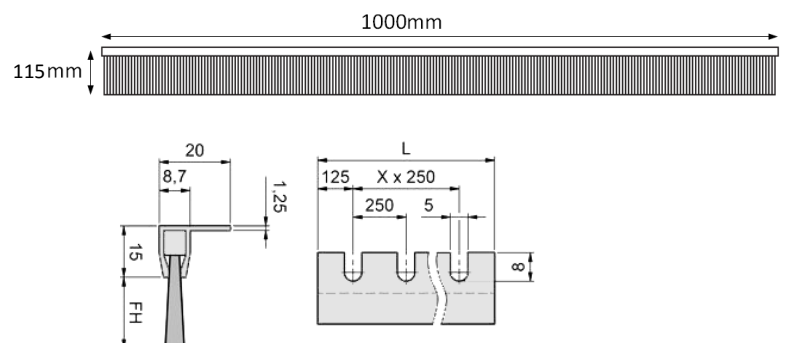

Ordering Information:

EZBR1000PNL02

EZIBLANK® 1000 Side Rack Brush



Data Centre, Power Monitoring & Air Flow Management Specialists.

Telephone +61 (02) 9690 2852
 Facsimile +61 (02) 9698 6952
 enquiries@idcsolutions.com.au
 www.idcsolutions.com.au